

LOB[®] 1000 E

MULTIFONCTIONS NDA LOBE PUMPS

Destemmed grapes harvest, must, wine

CARACTERISTIQUES

- Lobe pumps made of food grade hard Nitril rubber
- Low rotational speed
- Pump housing in 316 stainless steel precision
- Large range of flow from 100 to more than 1000 hl/h
- Electronic regulator
- Low oxygen dissolution (**a few µg/l**)
- Self-aspiration: 8 meters
- Rotational direction switch
- Continuous flow
- Pump trolley on stainless steel
- High pressure resistance (4.5 bars)
- High temperature resistance (-10 °C up to 90 °C)
- Hygienic: easy cleaning and maintenance



DIMENSIONS/ Weight: 300 kg

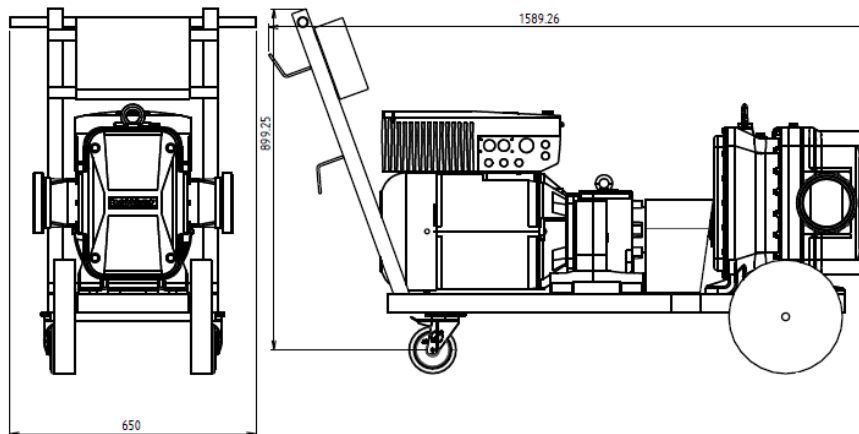

OPTIONS

- Radiocommande
- Pressostat
- Sonde détection manque de liquide

UTILISATIONS

- Transfer of destemmed grapes harvest, must with small solid particles, lees, juices, wines.
- Pumping over
- Filtration
- Bottling
- Able to empty pipes after transfers

PRINCIPE DE FONCTIONNEMENT

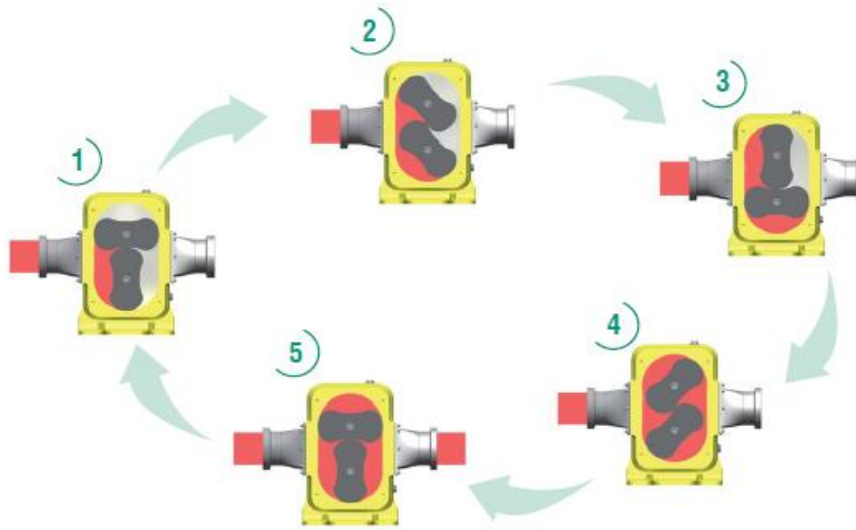

CURVES OF PERFORMANCE

Pression (bars)

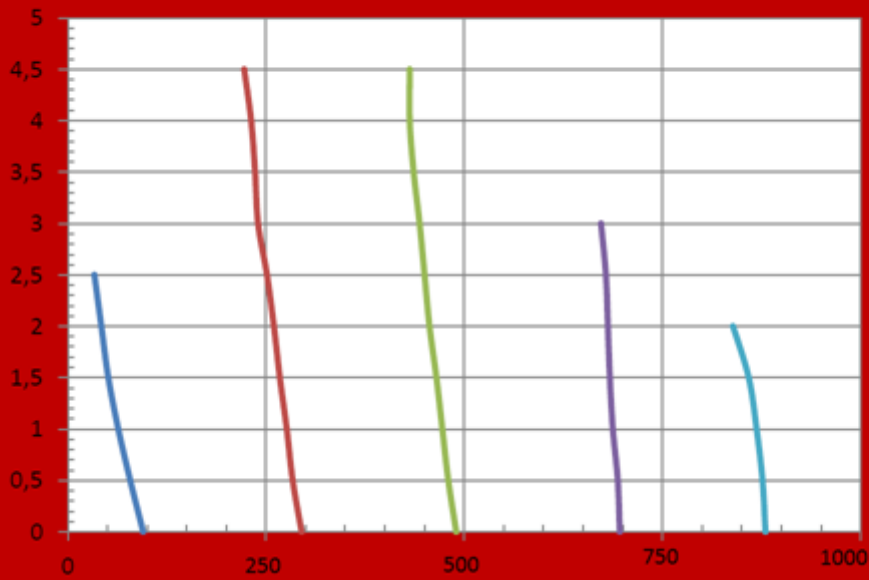

50 tr/min
150 tr/min
250 tr/min
350 tr/min
450 tr/min

Flow (hl/h)

Rounds/min	Frequency (Hz)	Flow (hl/h)	Pressure (bars)	Intensity (Ampères)
50	9	100 à 200	0 à 2.5	7.8 à 10
150	26.9	200 à 400	0 à 4.5	8 à 14.2
250	44.8	400 à 600	0 à 4.5	8.1 à 14.4
350	62.8	600 à 800	0 à 3	7.1 à 15.7
450	80.7	800 à 1000	0 à 2	10.4 à 15.6

TEST CONDITIONS

- Water at 10°C
- 12m and Ø 100mm inhalation pipe
- 6m expulsion pipe
- Flow measuring with Oenodeb®50

